

规格书/Specification

CUSTOMER/客户名称: _____

DESCRIPTION/产品类型: Encapsulated Transformer

CUSTOMER No./客户编号: _____

PRODUCT No./产品编号: UC30S-2-12020

Approved by customer/客户承认回签

Friendly Reminder: Please help to sign this Spec when approve , and fax to our company .

Or else, we will consider you have accepted it and make future order based on this Spec.

友情提示:请在签字确认后,按封面的传真号码回传给厦门同创兴科电子科技有限公司.如无回传,则视为

默认,后续的相关订单将以按本承认书的规定为技术要求.

MARKING 修改标记	REVISED CONTENT 修改内容	APPROVED & DATE 批准 日期

DATE/日期	2010/3/3	EDITION/版本	A0	PAGE/页码	1 OF 3
DRAFT/拟制	wen	CHECK/审核	winston	APPROVAL/批准	温玉冬

OUTLINE DRAWING(外形图):

UNIT(单位): mm

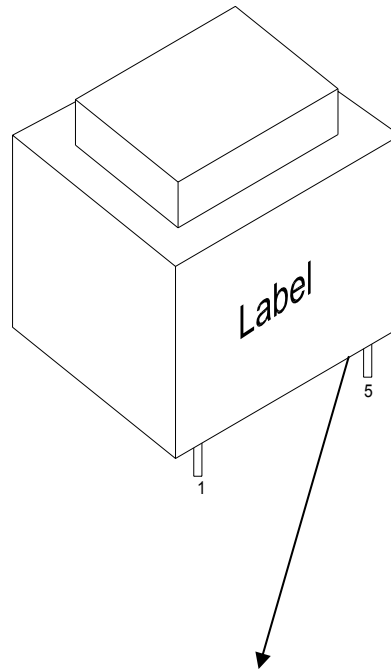
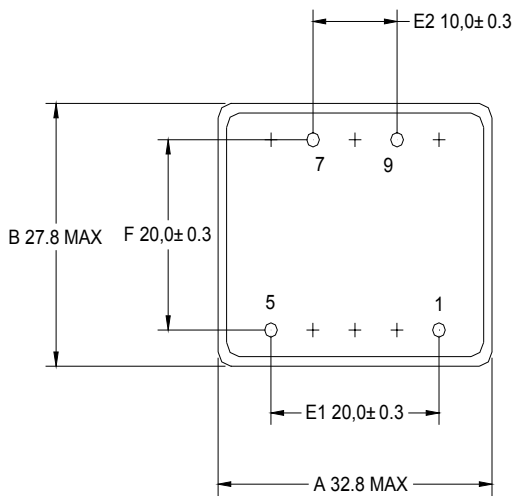
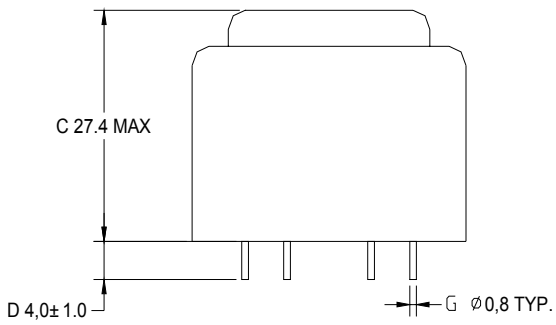

UC30S-2-12020		
230V	50/60Hz	1-5
12V	2.0VA	7-9
		ta 70/B

DATE/初始日期	2010/3/3	EDITION/版本	A0
PRODUCT NO./产品编号	UC30S-2-12020	PAGE/页码	2 OF 3

SCHEMATIC(电路原理图):

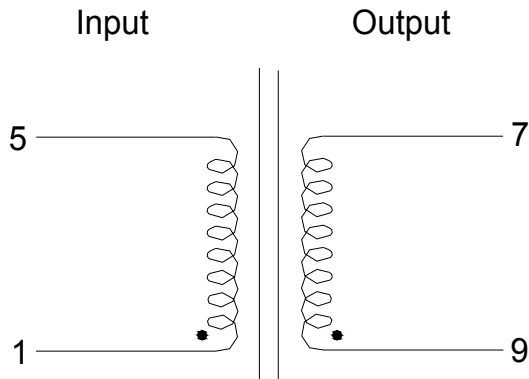

ELECTRICAL SPECIFICATION(电气特性测试):

ITEM(项目)	端子 TERMIANL	规格值 SPECIFICATION	测试条件 TEST CONDITION	测试仪器 TEST INSTRUMENTS
EXCITATION CURRENT 空载电流(mA)	1--5	11 MAX	Input: (1--5) 230V 50Hz	GDW 4032
LOSS POWER 空载损耗(W)	1--5	0.8 MAX		
Load Voltage 负载电压(V)	7--9	12±10% @ 167mA		
No-Load Voltage 空载电压(V)	7--9	20.7 Max		
RESISTANCE 直流电阻(Ω)	1--5	2420±10%	Ta=25°C	TH2512B
	7--9	26.8±10%		
绝缘阻抗 INSULATION RESISTANCE	P--S	100MΩ MIN	DC500V /1min	CS5603
HI-POT 耐压	P--S	4200V 1mA 1s	50Hz	

DATE/日期	2010/3/3	EDITION/版本	A0
PRODUCT NO./产品编号	UC30S-2-12020	PAGE/页码	3 OF 3